

DO Series

DC 360kW Power Cabinet

User Manual & Installation Instructions

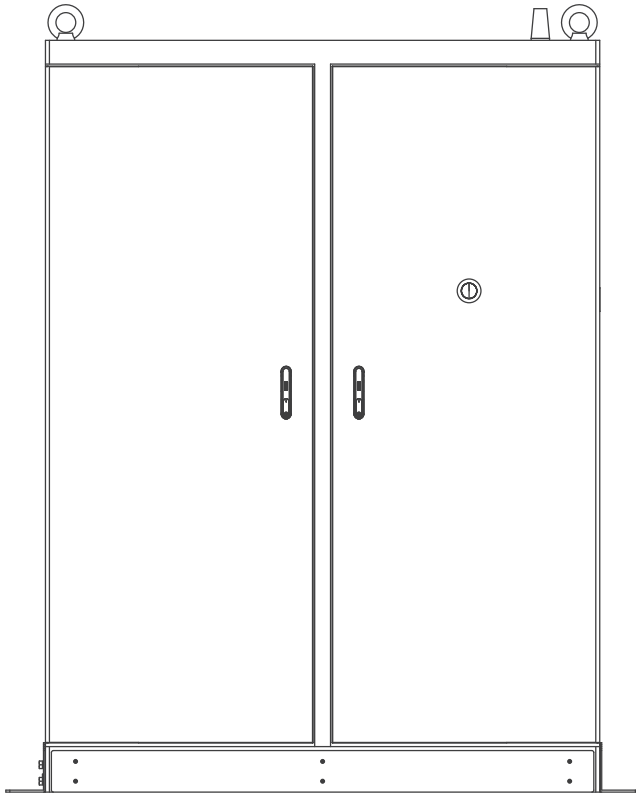

COPYRIGHT © 2021 Reserves the right to make changes to this product without further notice.
The customized appearance is subject to the customer's description.

CONTENT

Introduction	1
Features	1
Applications.....	1
1. Basic User Interface	2
2. Specification.....	3
2.1 Product Specification	3
2.2 Dynamic Power Sharing info:	5
2.3 Cable connection (TN system):	7
2.4 Dimensions	8
2.5 Direction of Cooling Airflow	8
3. Installation Instruction	10
3.1 Before Installation	10
3.2 Grounding and Safety Requirements	16
3.3 Unpack the charger	17
3.4 Recommended Tools for Installation and Inspection.....	20
3.5 Installation Procedure	23
3.6 Installation Inspection & Commissioning	37
Screw torque requirement table	39
4. Charger and Network Setting	41
4.1 Wi-Fi Network Setting	41
4.2 3G/4G Setting.....	43
5. Maintenance	45
5.1 Status Codes	45
5.2 General Maintenance	45
5.3 Replacement Kits and Accessories	47
6. Limited Product Warranty.....	48
Appendix 1 - Package list.....	50
Appendix 2 - Wire and NFB recommendation	51

Introduction

The DC Power Cabinet Fast Charger is the top choice to power battery electric vehicle (BEV) and plug-in hybrid electric vehicle (PHEV). It is designed for quick charging in both public and private locations, such as retail and commercial parking spaces, fleet charging station, highway service area, workplace, residence, etc.

The DC Power Cabinet Fast Charger has the advantage of easy installation. The pluggable power modules realize flexible and cost-effective installation for different types of locations. The DC Power Cabinet charger also has network communication capability. It is able to connect with remote network systems and provide drivers of electric cars real-time information, such as the location of charging stations, charging progress and billing information. The DC Output Power Cabinet Fast Charger has a clear user interface with function buttons, safety certifications and an excellent waterproof and dust proof design to provide the best choice for outdoor environments.

Features

- Pluggable power modules make installation easy and flexible.
- Offers customers the convenience of start/stop charging control from an authorized RFID smart card or mobile APP.
- Built according the latest industry standards.
- Carries an outdoor rating capable of withstanding solid and liquid intrusions in outdoor settings making the unit more stable and highly reliable.
- Provides a high-contrast, screen interface with multi-function buttons.
- Upgradeable to simultaneously 4 DC charging, up to 360KW per output with liquid-cooled connector up to 500A.

Applications

- Public and Private Parking Area
- Community Parking Area
- Parking Area of Hotel, Supermarkets and Shopping Malls
- Workplace Parking Area
- Charging Station
- Highway Rest Area

1. Basic User Interface

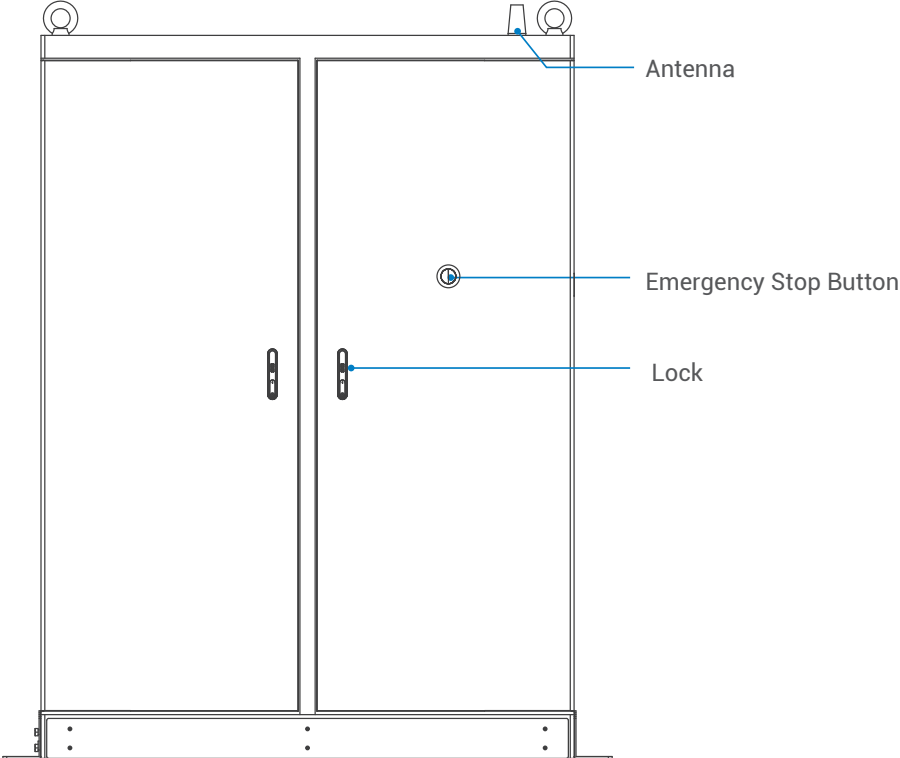

2. Specification

2.1 Product Specification

Model Name		DOWx362 Series
AC INPUT	*Input Voltage	480 VAC, 3 Phase, (+10%, -15%) (408 ~ 528 VAC)
	*Input Current Rating	465 A @ 277Vac 573 A @ 235Vac
	Electrical Distribution	3P+ N+ PE (Wye Connection)
	Power Grid System	TN/TT
	Frequency	50/60Hz
	*Max. Input Power	396 kVA
	Power factor	> 0.99
	Efficiency	> 94% (at full load)
DC OUTPUT	Maximum Output Voltage	950VDC
	Simultaneously output mode	0%, 25%, 50%, 75%, 100% of 360kW
	Voltage Accuracy	±2%
	Current Accuracy	±2%
Electrical Isolation	Isolation between input and output	
Standby Power	< 100W	
Communication	External	Ethernet+WiFi+3G/4G
	Internal	CAN Bus/ RS485
Input Protection	OVP, OCP, OPP, UVP, SPD	
Output Protection	SCP, OCP, OVP, LVP, OTP	
Internal Protection	OTP, AC contactor detection, DC contactor detection, Fuse detection	
*AC breaker capacity selection	Current rating of NFB be over than or equal to 600Amp (360kW)	

User Interface & Control	Display	None
	User Authentication	None
	Backend support	OCPP 1.6 JSON
Environmental Conditions	Operation Temperature	power derating when over 50°C
	Storage Temperature	-40°C to 70°C
	Relative Humidity	5%~95% RH, non-condensing
	Altitude	≤ 2000m (6561')
Regulations	Safety	UL2202, UL2231
	EMI/EMC	FCC CFR Title 47 Part 15 Subpart B: 2020 ANSI C63.4: 2014 ICES-003:2020 Issue 7
Mechanical Specifications	Dimensions (WxDxH)	1400x800x1900 mm (55.12"x31.50"x74.80")
	Weight (typ.)	< 1200 kg (2645.55 lb)
	DC outputs interface	Terminals x 4 sets
	Cooling	Forced Air
	Ingression Protection	NEMA3R
	Anti-vandalism	IK10 (not including screen and RFID module)

* Refer to Appendix2

2.2 Dynamic Power Sharing info:

Dynamic Power Sharing (Four-Connector Model Only). According to the standard 360kW power cabinet DC output, the power dispenser connectors maximum output as below list:

1. The connectors will get equal sharing (90kW each) output power when four connectors are plugged in simultaneously. If any particular specification, please contact the manufacturer for more information.
2. Each connector will get 180KW (50%) output power when only two connectors are plugged in simultaneously in separate dispenser or the rest two connectors finish the charging session.
3. The connectors will get 90KW (25%) and 270KW (75%) output power when only two connectors are plugged in simultaneously in same dispenser or the rest two connectors finish the charging session.
4. The connectors will get 90KW (25%), 90KW (25%) and 180KW (50%) output power when three connectors are plugged in simultaneously or the fourth connector finishes the charging session.

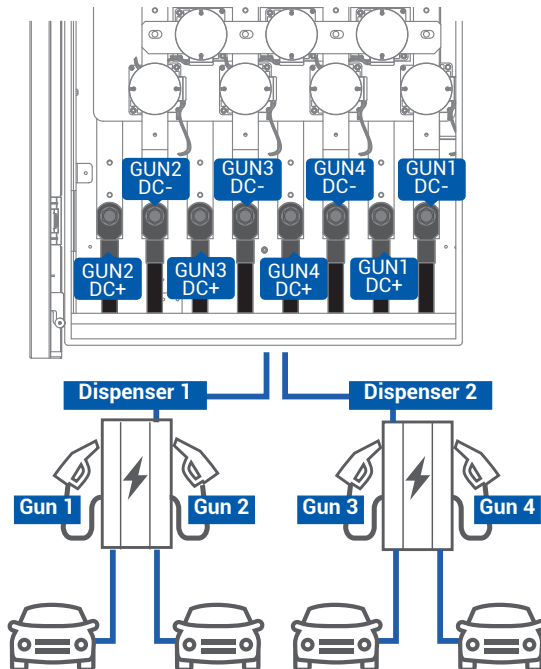

	Gun 1	Gun 2	Gun 3	Gun 4
One Car	360kW	X	X	X
Two Cars	180kW	180kW	X	X
Two Cars	180kW	X	180kW	X
Two Cars	90kW	X	X	270kW
Three Cars	180kW	90kW	90kW	X
Three Cars	X	90kW	270kW	X
Three Cars	90kW	180kW	X	90kW
Three Cars	90kW	90kW	180kW	X
Three Cars	X	90kW	90kW	180kW
Three Cars	90kW	90kW	X	180kW
Three Cars	90kW	X	180kW	90kW
Four Cars	90kW	90kW	90kW	90kW

2.3 Cable connection (TN system):

*Adapted for two cabinets version

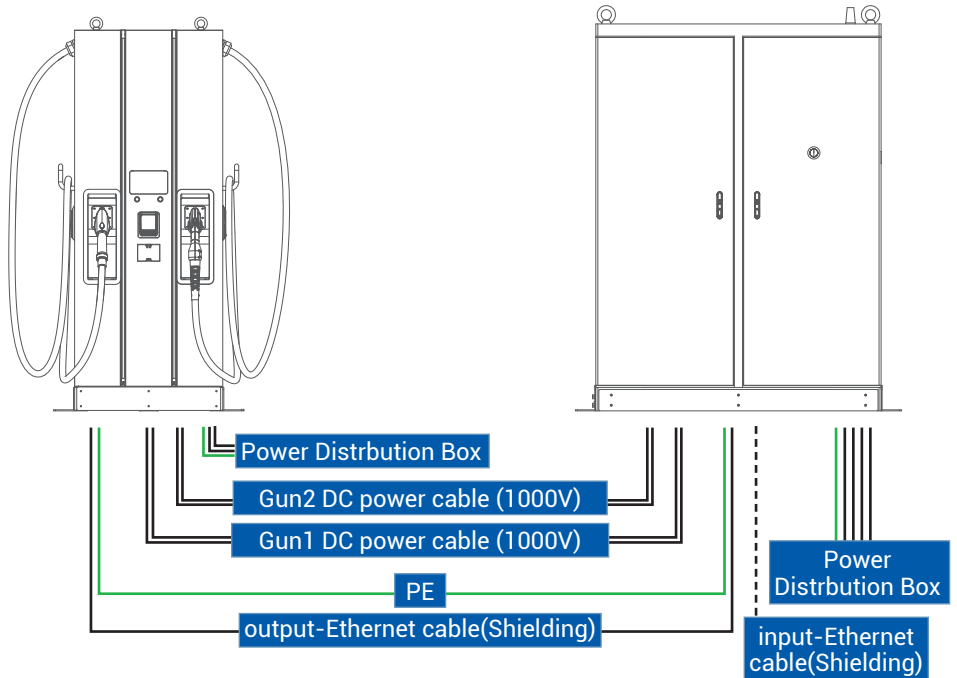

NOTE:

- The maximum DC voltage would be 950Vdc, the DC power cable be used should be able to withstand at least 1000V and required safe ampere capacity.
- Please note and confirm that all installation assemblies must comply with national safety standard and codes.
- The max. allowable distance between the power cabinet and the dispenser is 30m.
- The power cabinet and the distribution box are recommended to keep distance from the end users to have better operation experience.
- The similar design concept in appearance is recommended to the power cabinet and the distribution box.
- Must use the CAT6 SFTP cable 24AWG or 26AWG with CAT6A FTP RJ45 Plug or higher level cable/PLUG increased shielding for ethernet contact.

2.4 Dimensions

Unit:mm(inch)

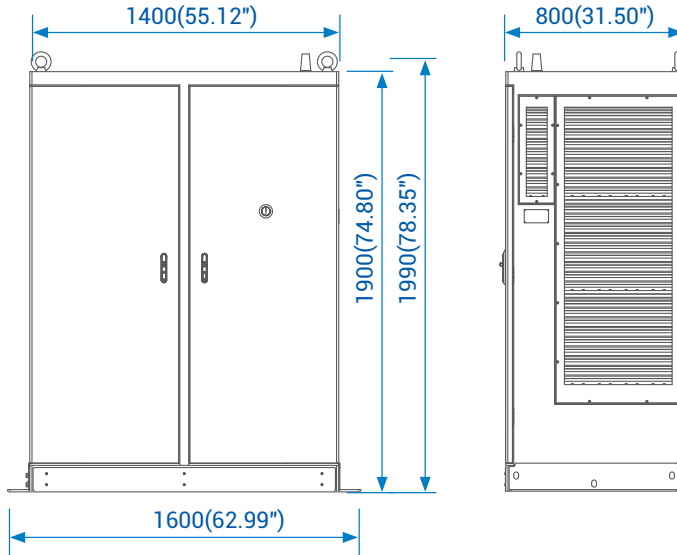

2.5 Direction of Cooling Airflow

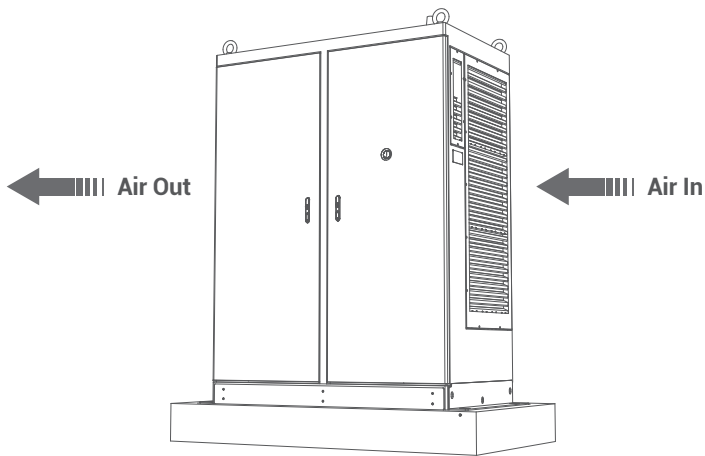

The following signs are used on the equipment and in this manual:



DANGER

Hazardous voltage

Identifies a hazard that could result in severe injury or death through electrocution.



WARNING

Various

Identifies a hazard that could result in severe injury or death.



WARNING

Rotating parts

Identifies a hazard that could result in injury due to the presence of rotating or moving parts.



WARNING

Pinch Hazard

Identifies a hazard that could result in injuries in which some body parts are pinched or crushed.



CAUTION

Various

Identifies a hazard that could result in damage to the machine, other equipment, and/or environmental pollution.



NOTICE

Contains remarks, suggestions or advice.

3. Installation Instruction

3.1 Before Installation

- Read all the instructions before using and installing this product.
- Do not use this product if power cable or charging cable have any damage.
- Do not use this product if the enclosure is broken, open or has other damage.
- Do not put tools, materials, fingers or other body parts into the charger or EV connector.
- The product should be installed only by a licensed contractor, and/or licensed technician in accordance with all building codes, electrical codes and safety standards.
- The product should be inspected by a qualified installer prior to initial use. Under no circumstances will compliance with the information in this manual relieve user of his /her responsibilities to comply with all applicable codes and safety standards.
- Power feed must be 3 Phase Wye Connection with one of TN/TT grounding systems.
- The capacity of power supply should be higher than 198kVA (180kW application) or 396kVA(360kW application) in order to have function correctly.
- The product should be installed in a free air area and need sufficient space for product installation and maintenance, keep at least 100cm(39.37") clearance distance to the product

3.1.1 Contractor Safety guide

Introduction

- A safe work environment for everyone - participants, installation and demolition crews, contractors and subcontractors.
- Ultimately, it is the responsibility of contractors to ensure the safety and safe work practices of their employees and subcontractors who may be working at the site on their behalf.
- This guide provides a simple reference guide with basic rules for implementation. This guide does not outline every single safety standard: it is designed to be a supplement to participants, contractors and subcontractors.
- Contractors, subcontractors and employees should cooperate with their employers and other persons in complying with safety regulations and instructions.

In particular, employees should:

1. Obtain the qualified authorization of the responsible unit in the construction area.
2. Work safely.
3. Not do anything to endanger themselves or other persons.
4. Use personal protective equipment as required and take reasonable care of it when it is not in use.
5. Report unsafe activities immediately to supervisors or the responsible person in control of the workplace.
6. Report all accidents and dangerous occurrences to the supervisor immediately after they happen.

1. Requirements for workplace conditions

- Set up suitable fencing to isolate the construction area from outside.
- Close and secure all entrances when the site is unattended.
- Hang warning notices nearby which show the following information: warning icon and phone number of person in charge.
- Install sufficient lighting fixtures.



2. Cleaning up

- Keep work areas (including accessways) free from debris and obstructions.
- Keep ground surfaces tidy and flat, to avoid people tripping or being hurt by tools or other objects.
- Stack and store equipment and materials in a tidy and stable manner.
- Regularly clean up and dispose of waste.
- Remove all surplus materials and equipment after completion of work.



3. Fire hazards

- Beware of flammable materials and goods. Keep them away from work areas.



4. Protection against high temperatures on the worksite

- Erect a sunshade or shed to shelter workers from the heat and sun
- Set up cooling equipment, such as exhaust fans
- Make water dispensers available
- Provide suitable protective clothing such as hat, sunglasses and long sleeves to protect workers from heat stroke and UV rays



5. Inclement weather

- Secure all scaffoldings, temporary structures, equipment, and loose materials
- Check and implement SOP to ensure disconnection of gas supplies, electrical circuits and equipment
- Inspect worksites to ensure protection against ingress of water or dust
- Inspect the drainage system for blockages and remove if found
- Stop all outdoor works except for emergency works

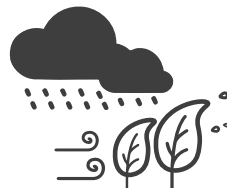

6. Ladders

- Only use ladders that meet local safety regulations
- Do not use wooden ladders
- When working at height, it is recommended to use platforms instead of ladders
- If using a platform is not practicable, a supervisor should assess the potential risk and provide safety
- protection equipment for workers
- Use non-conductive ladders made of glass-fiber or reinforced plastic when carrying out electrical work
- Assign assistants to provide support when working on ladders
- Check all ladders for broken rungs or other defects before use and periodically
- Fully open stepladders when in use
- Do not stand on the top two rungs of a ladder



- Do not overreach when working on a ladder
- Beware of overload restrictions

Country	Standards
British	BS1129,BS2037,EN131,EATS13/1
USA	ANSI A 14.1,ANSI A 14.2,ANSI A 14.5
Australia New Zealand	AS 1892.2-1922,AS/NZS1892.1,AS/NZS 1892.3
Canada	CSA Z11 M81

Common Standards for Ladders

7. Working at height

- Avoid working at height by using alternative tools and methods as far as practicable
- It is strongly recommended to build suitable scaffolding or work platforms
- Provide fall arrest systems for workers if it is impracticable to use working platforms
- Secure all materials and tools to prevent them falling from height

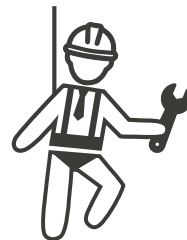

8. Lifting operations

- Have lifting gear and apparatus regularly inspected and tested by qualified persons
- Isolate and cordon off lifting areas to keep out non-construction personnel
- Ensure that lifting routes do not cross buildings or people, and avoid collision with objects
- Do not exceed safe working load limits



9. For on-site workers

- Plan all work
- Turn off power (work with live parts de-energized whenever possible)
- LOTO (Lock Out, Tag Out)
- Live electrical work permit (input terminals with HV after door open)
- Use personal protective equipment (PPE)
- Safe workplace conditions and space
- Adhere to other occupational health, safety and security codes, such as those published by OSHA

10. Reference standards

Adhere to the following codes:

- NFPA-70E -2021 Sec 110.3 (Electrical Safety in the Workplace)
- NFPA-70E -2021 Sec 130.4 (Shock Risk Assessment)
- NFPA-70E -2021 Sec 130.5 (Arc Flash Risk Assessment)

3.2 Grounding and Safety Requirements

- The product must be connected to a grounded, metal, permanent wiring system. Connections shall comply with all applicable electrical codes. Recommend ground resistance is less than 4 ohm.
- Ensure no power is connected at all time when installing and maintaining.
- Use appropriate protection when connecting to main power distribution network.
- Use appropriate tools for each task.

3.2.1 Service Wiring

- Ground Connection (TN System)

Always connect the Neutral at the service to Earth Ground. If ground is not provided by the electrical service then a grounding stake must be installed nearby. The grounding stake must be connected to the ground bar in the main breaker panel and Neutral connected to Ground at that point.

- 480Vac Three-Phase(Line to Line)



CAUTION!

This is feed from 3 Phase / Wye Connection power grid, the DC Cabinet Fast Charger should connect to L1, L2 or L3, and Neutral. Earth ground must be connected to neutral at only one point, usually at the breaker panel.

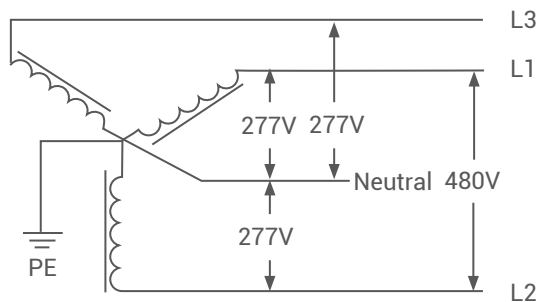

480V Three-Phase Wiring Connection

3.3 Unpack the charger

- The product is Direct current (DC) charger, the packing design passed the packaging simulation test, if the packaging is damaged cause by overturning, falling or external impact during transportation, it may cause the product damage or defects. if there is any serious damage to the packaging when receiving the goods, please notify manufacturer about your findings.
- Receiving the DC 360kW Power cabinet. The product is delivered by a transport company to a warehouse or specified location where it will be handed over. Transporting the DC 360kW Power cabinet to its final location (last mile service) is not standard included in the order.

NOTICE: The delivery truck unloads the pallet carrying the DC 360KW Power Cabinet. The movement of the DC 360kW Power cabinet to its final location is the responsibility of the customer / contractor.



- Checking the TiltWatch PLUS sensors: If the TiltWatch PLUS indicator is tilted over 30°
 1. Do not refuse the delivery / receipt.
 2. Make a notation on the delivery receipt and inspect cabinet for damage.
 3. If damage is discovered, leave cabinet in original package and request immediate inspection from carrier within 3 days of delivery.
 4. Contact manufacturer by mail or phone to notify us about your findings



WARNING!

Charger weight with packing may > 1200 Kg(2645.55 lb)!
Be careful during unpack process.

STEP 1.

Please disassemble the shipping crate as follows:

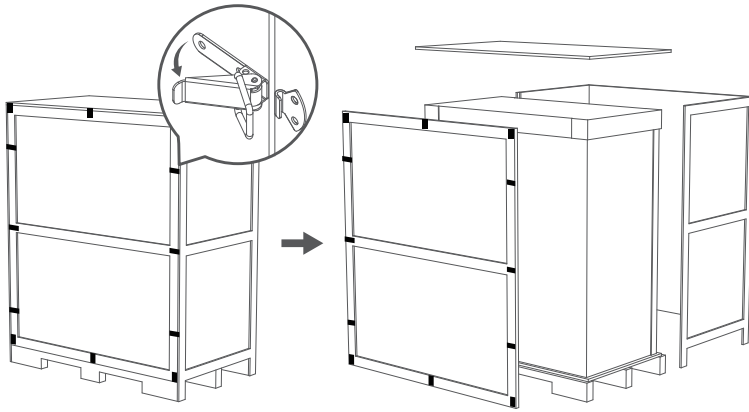

STEP 2.

Please remove the cardboard box and the protective internal packaging as follows:

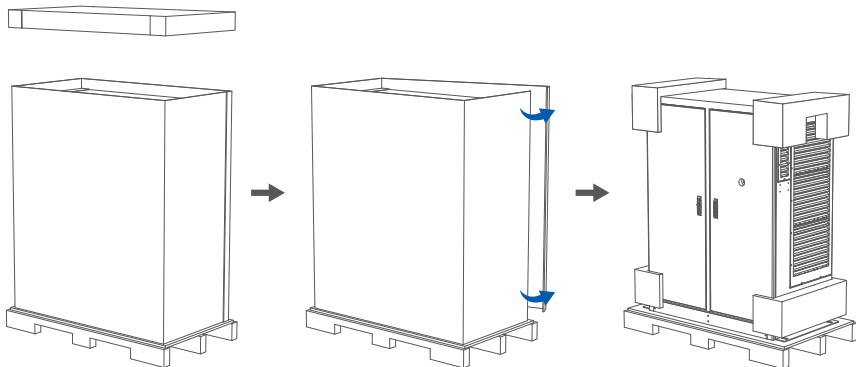

STEP 3.

Remove the 4 fixing screws.

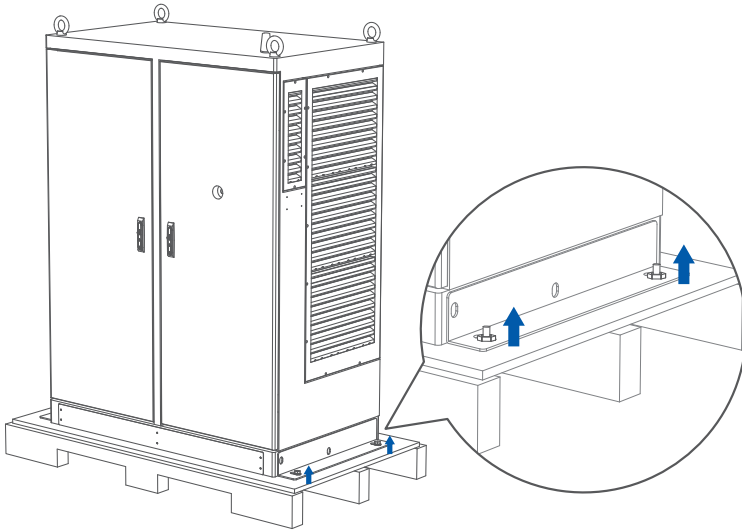

Note

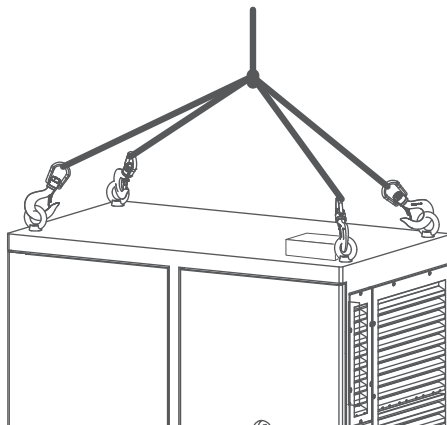

To use lifting eye bolts to move the EVSE, please apply 6mm (1/4 inches) diameter steel wire rope to the four eye bolts as following picture. (Make sure to tighten the eye bolts before lifting.)



3.4 Recommended Tools for Installation and Inspection

3.4.1 Recommended Tools and assemblies for Installation

Type	Description
Philips Screwdriver	No.1, No.2
Hexagon Screwdriver	5.5mm, 7mm, 8mm, 10mm,13mm, 17mm, 19mm, 24mm, 30mm *See the table of metric conversion
Shifting Wrench	12" (34mm)
Electrical tape	Black/15mm (0.6") Width
Combination wrench (for DC /PE CABLE)	FNW-19, FNW-24
AC Input Cable	<p>Conductor cross section: 250mm² (500MCM) at least, Cable x 8; L1x2, L2 x2, L3x2, Nx2. (360kW) MAX With Ring terminal for M16 screw (Inner diameter > 16mm (0.63"), Outer diameter < 51mm (2"); thick type). Recommend to use 600V, 90° C (194°F), XLPE or Hypalon power cable.</p> <p>Protective Earth conductor : Conductor cross section: 200mm² (400MCM), cabledx1 for TN system With ring terminal for M16 screw (Inner diameter > 16mm(0.63"), Outer diameter < 51mm (2") ; Thick type) (Conductor cross section: 200mm² (400MCM) ground rod for TT system)</p>
DC Power Cable & PE	<p>DC Output x2 (Gun1, Liquid cooling; Gun2, Natural cooling) (The charging connectors installed on the EVSE may vary depending on the designated application.)</p> <p>Each connector is recommended to use below cable: Liquid Cooling 500A CCS1/CCS2-Conductor cross section: Conductor cross section: 125 mm² (250MCM) at least, Cable x 4 (DC+ x2, DC- x2)</p> <p>Natural Cooling 300A CCS1/CCS2- Conductor cross section: 150 mm² (300MCM) at least, Cable x 2 (DC+ x1, DC- x1)</p> <p>Natural Cooling 200A CCS1/CCS2, CHAdeMO 200A Conductor cross section: 125mm² (250MCM) at least, Cable x 2 (DC+x1, DC- x1)</p> <p>With ring terminal for M16 screw (Inner diameter > 16mm (0.63"), Outer diameter < 40mm (1.57"); Thick type)</p>

	 Recommend to use 1000V, 90°C (194°F), XLPE, Photo-Voltaic or Hypalon power cable.  Protective Earth conductor: Conductor cross section: 200mm ² (400MCM) cable for TN system With ring terminal for M16 screw (Inner diameter > 16mm (0.63"), Outer diameter < 40mm (1.57"); Thick type) (Conductor cross section: 200mm ² (400MCM) ground rod for TT system)
Ethernet cable	CAT. 6 SFTP cable 24AWG or 26 AWG x 2 for dispenser cabinet.
Slotted Screwdriver	
Socket driver	
Forklift	
Wire Stripper	
Wire cutters	
Residual Current Device	30mA type A , 4 pole
No Fuse Breaker	over than or equal to 600A 4 pole; B curve

Please follow all local safety standards and electrical codes at all times, even if the actual installation process and procedures are varied to accommodate the existing site condition.

SCREW SIZE		RECOMMENDED TORQUE			
METRIC (MM)	ENGLISH (inches)	DIN(Nm)		ASTM (ft'lb)	
		6,9 QUALITY	8,8QUALITY	A449 TYPE	A325TYPE
M3	1/8	1	1,3	-	
M4	5/32	2,5	3		
M5	3/16	4	6		
M6	1/4	5	10	4	
M8	5/16	20	23	9	
M10	7/16	40	50	25	
M12	1/2	60	70	38	50-58
M14	9/16	100	120	54	-
M16	5/8	150	210	75	99-120

3.4.2 Recommended Tools for Inspection & Commissioning

Type	Description
EV or EV Simulator	Meet CCS1, CCS2 & CHAdeMO standard
Multimeter	1000V
Current Probe	600A
RFID Authorized Card 2	
Door Key 2	
Needle-Nose	
Laptop & CAT6 Cable	
Wi-Fi, 3G/4G signal quality checker	If wireless router is used, please do not leave the router in metal box for better signal strength.

3.5 Installation Procedure

3.5.1 Required space for placing and maintaining

required a space of 2600 x 1600 mm. This space is calculated as follows:

- Size Charge W x D x H: 1400 x 800 x 1900 mm.
- Front side 850 mm, in order to open the front door.
- Left and right side 600 mm, in order to open left and right door.
- Backside 100 mm, in order to guarantee an unimpeded airflow.
- The distance from ground screws to the RC concrete edges should be at least 100mm.

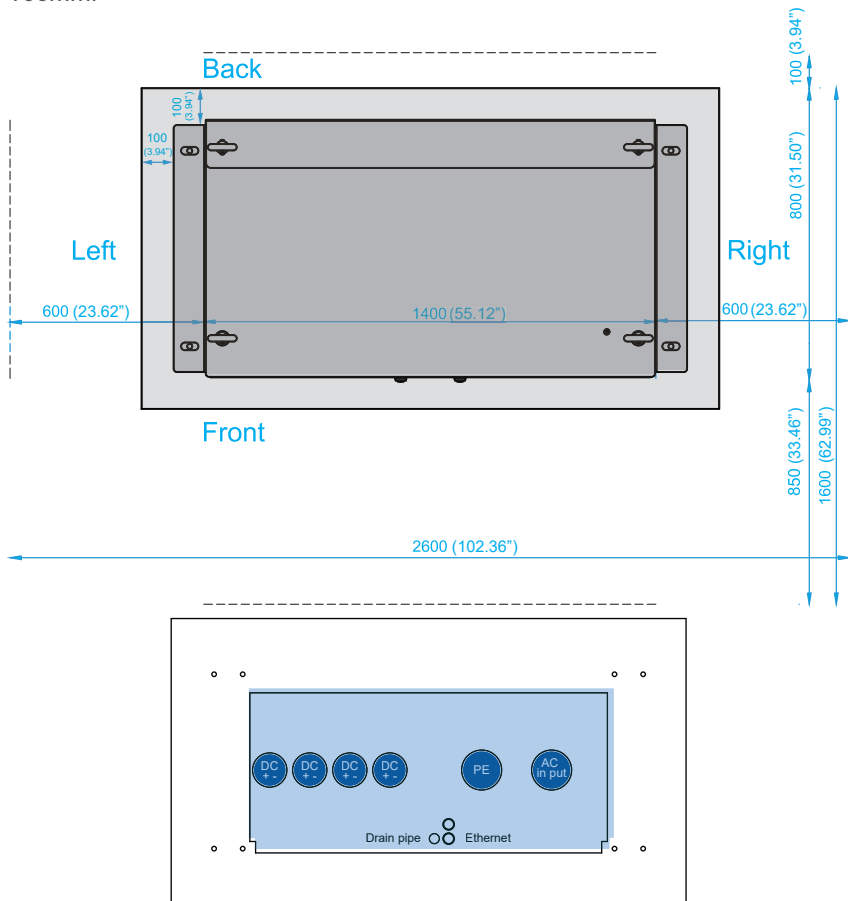

3.5.2 Build concrete base

STEP 1.

- 1- Build 1800mm(72") x 1000mm(40") x 200mm(8") concrete base on the level to stand charger in advance.
 - 2- Implant 5" conduit for AC input cable, 5" conduit for PE cable , 4" conduit for DC output cable, 1" conduit for Ethernet, 1" drain pipe.
 - 3- And install the 4 pcs of M16 mounting anchor bolts and leave at least 50mm(2") thread length enough for 2 pcs of M16 nuts to be fasten on each after the unit has been fitted onto the base. The positioning of these 4 pcs of M16 screws should be within ± 2 mm in short axis, ± 2 mm in long axis according to screw holes of charger.
 - 4- Add drain pipe at opening of concrete base to prevent water/moisture accumulation.
- *Recommend to use a prefabricated steel mold for constructing the cement concrete base per dimensions provided below.

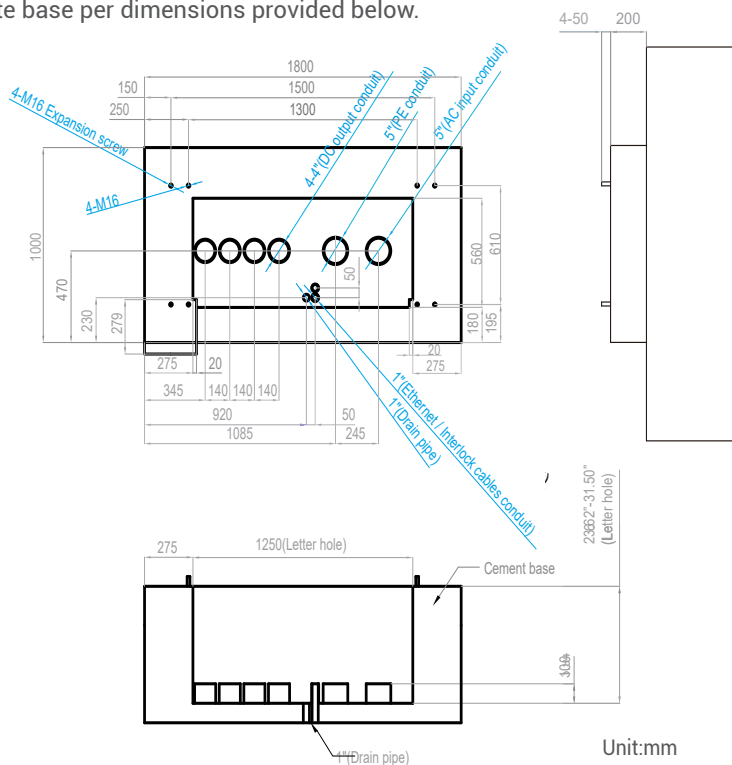

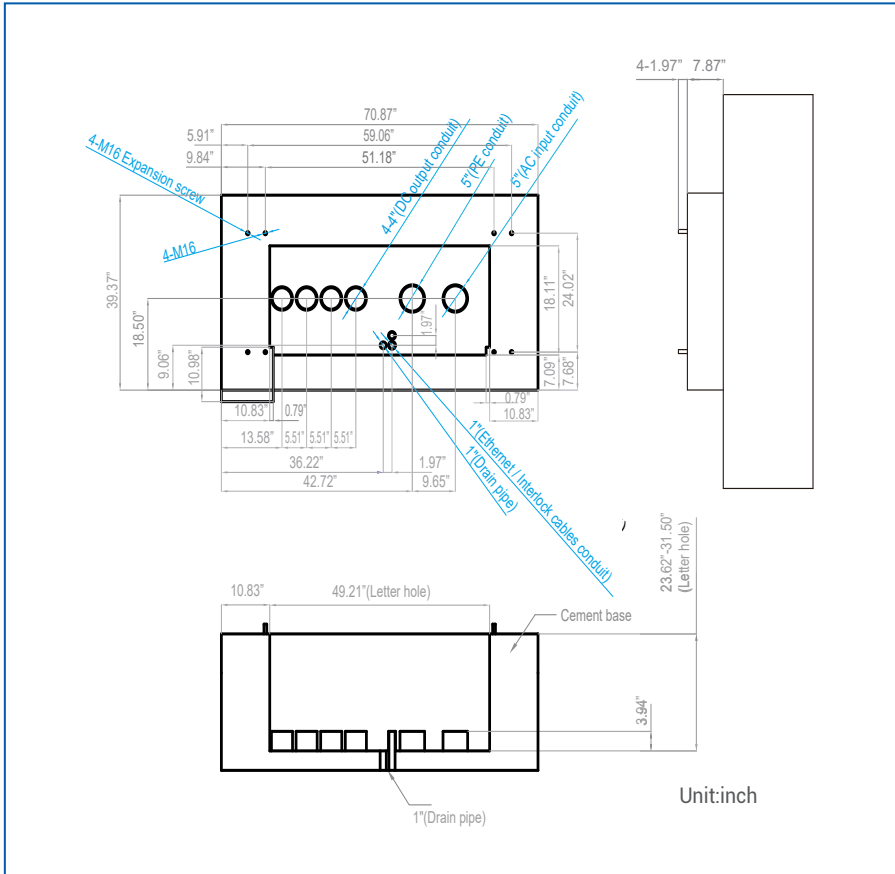

STEP 2.

- Extend 3 phase 5 wires AC input cable from conduit of concrete base, AC cable expose at least 370mm(15"), PE cable expose at least 300mm(12") and these wires should be with ring terminals.
- The conductor cross sectional area of input power wires should be not less than 250mm²(500MCM). Extend 8 wires DC output cable from conduit of concrete base, DC cable expose at least 320mm(13") and these 8 wires should be with ring terminals. The conductor cross sectional area of output power wires be recommended at section 3.4.1.
- Extend communication wire from conduit of cement base, expose at least 280mm(12").

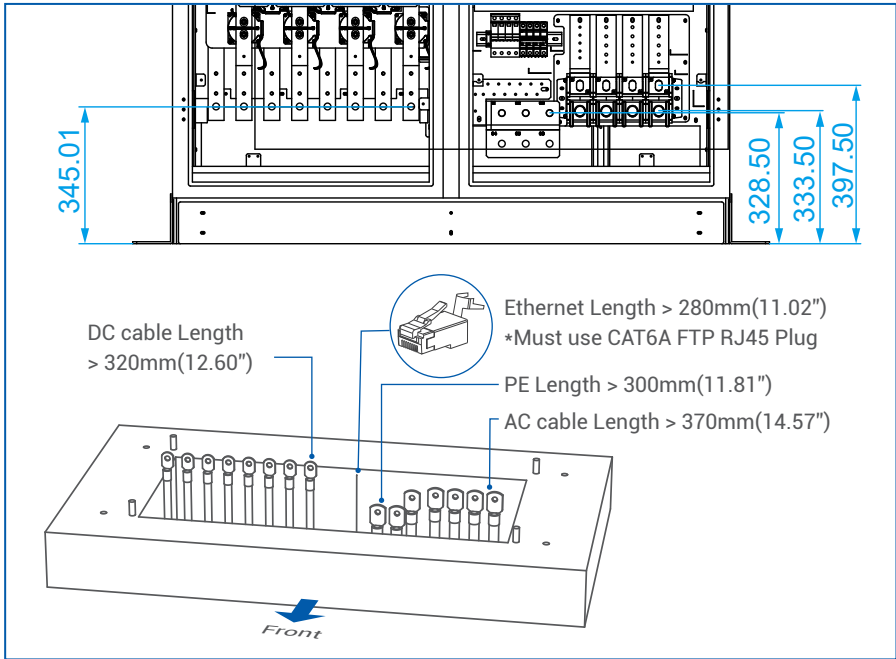

3.5.3 Two Methods of Fixing the Charger method1

Method 1.

Lift the charger onto the concrete base, feed all the cables through the entry hole located at the bottom of the unit; fasten the 4 pcs of M16 screw nuts on the 4 pcs of M16 mounting anchor bolt from the cement base (2 nuts for each bolt) to secure the chargers.

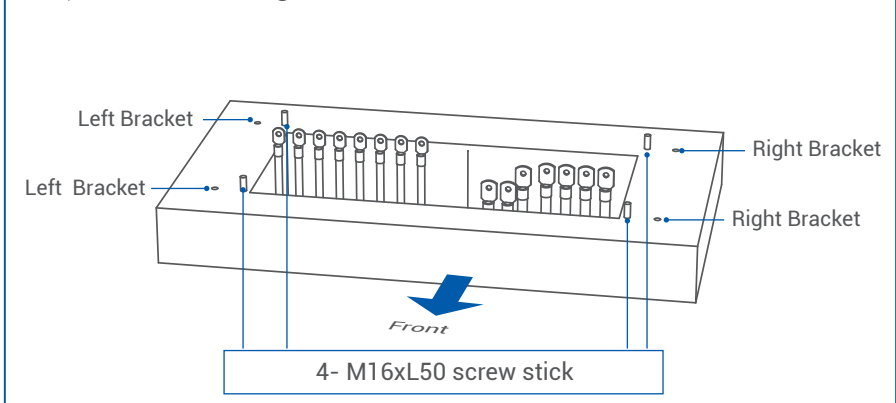

Method 2.

Fix the cabinet with external brackets and expansion bolts.
Lift the cabinet onto the concrete base, remove the cover metal sheet of the cabinet base, fix the L-shaped brackets on the cabinet base with the M16xL120 expansion screws (Material: Stainless steel), drill 4x $\Phi 20$ mm screw holes on the concrete base, secure L-shaped brackets on the concrete base by 4 pcs M16 expansion bolts (Material: Stainless steel).

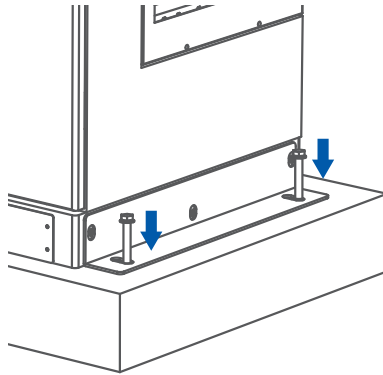

Note

Remove the protective antenna EPE.
If remove the eye bolts on the top of the cabinet, must assemble the water-proof plastic bolts (in the accessory pack).

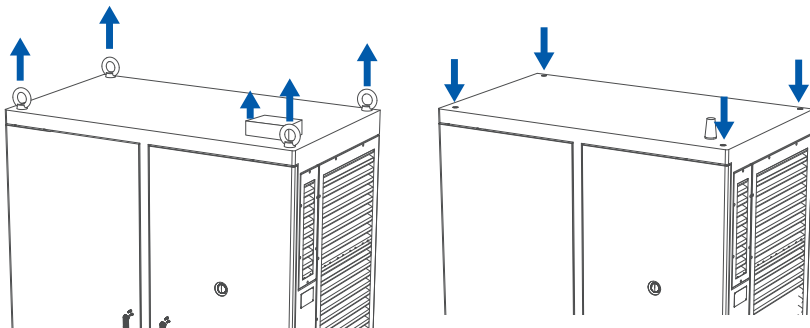

STEP 2.

Unscrew 4 pieces of M5 screws of the 2 back covers, and 2 pieces of M5 nuts. Originally, the middle nuts of back cover is half loose and so can take the 2 back covers after unscrew the screws and nuts.

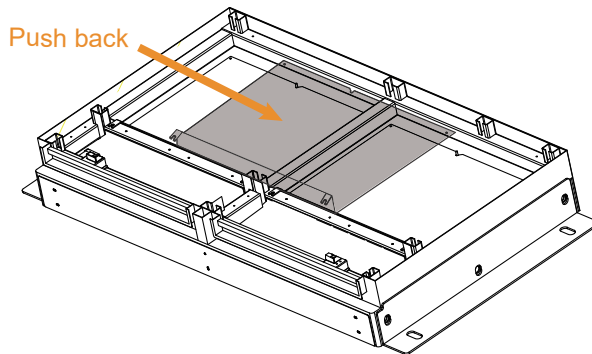
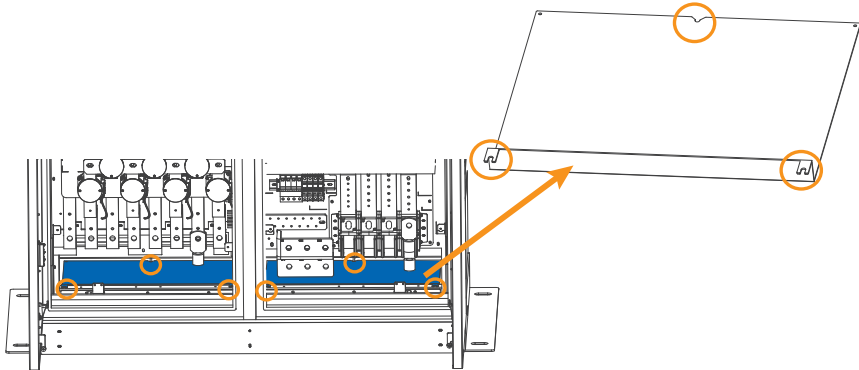

*The purpose for the cover is prevent from invasion of insect or small animals
It can be removed while installing if needed, just loosen screws on the cover,
but remember to make cover fixed as original after installation

3.5.4 Pre-work for lifting

STEP 1.

Open front door for wiring, loosen 6pcs of screws to remove 2 set of cover plate .

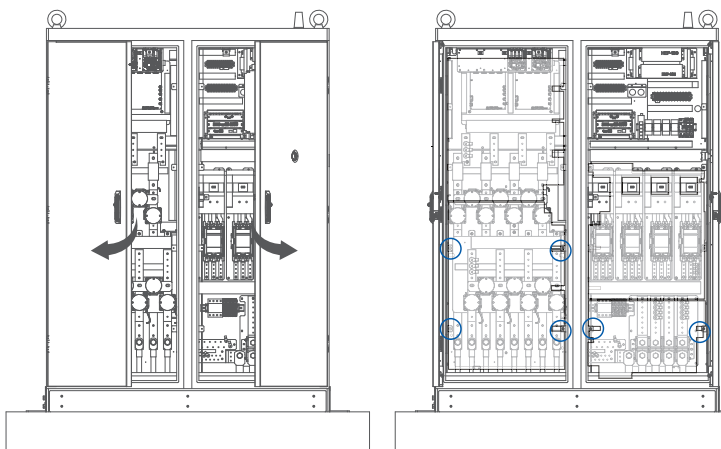

STEP 3.

Unscrew the 1 piece of M5 screw of the two front covers and 8 pieces of M5 nuts, after that to take out the front cover.

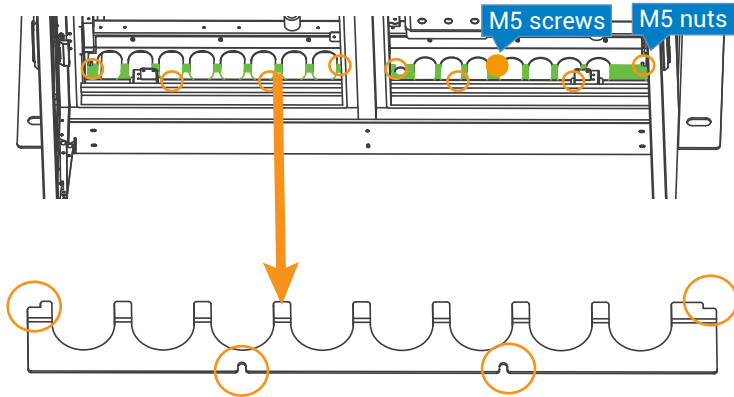

STEP 4.

To use lifting eye bolts to move the EVSE, please apply 6mm (1/4 inches) diameter steel wire rope to the four eye bolts as following picture. (Make sure to tighten the eye bolts before lifting.)

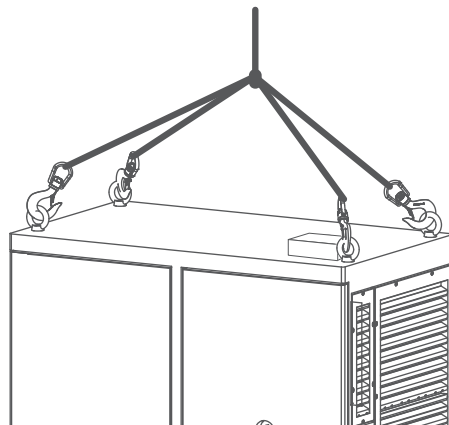

Or use a forklift to move the EVSE.

Step 1. Please remove the front and rear bottom trim panels first.

Step 2. Use a forklift to raise the EVSE.

(the fork must be opened to the maximum state)

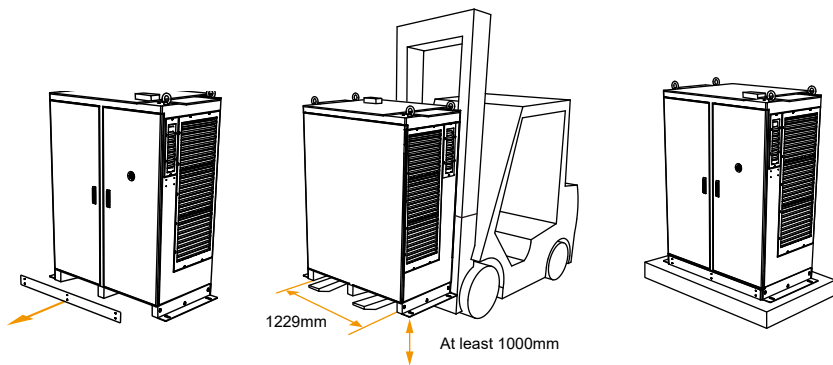

STEP 5.

Arrange the wires to be pre-bended , and lift the EVSE.

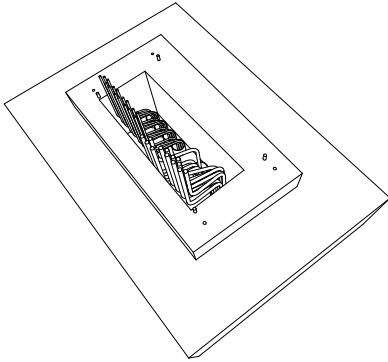

The situation of pre-bending wires in RC concrete base .

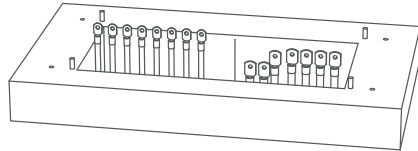
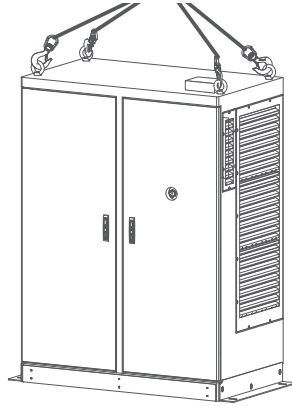

STEP 6.

Fix the cabinet with external brackets and expansion bolts.
Lift the cabinet onto the RC concrete base , remove the cover metal sheet of the cabinet base , fix the L-shaped brackets on the cabinet base with the M16xL120 expansion screws (Material: Stainless steel), drill 4x $\Phi 20$ mm screw holes on the RC concrete base , secure L- shaped brackets on the RC concrete base by 4 pcs M16 expansion bolts (Material: Stainless steel).

Installation Precautions: During install the charging or stand, must ensure the equipment levelness to avoid the tilting of charging equipment affect the accuracy of tilt sensor operation.

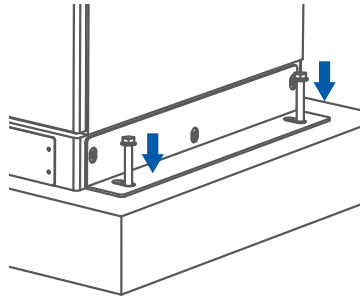

3.5.5 Installing Cable

STEP 1.

Put the pre-bending wires to to the front cover, and then put the back cover back. After put back, screw 1 pieces of M5 screws of the two front covers and 8 pieces of M5 nuts.

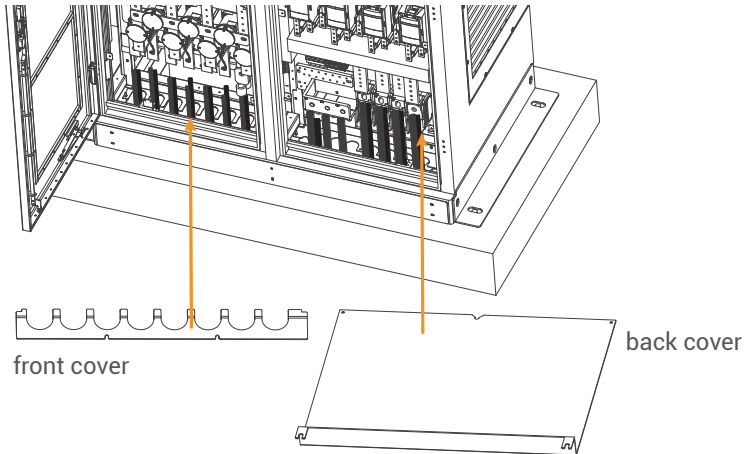

STEP 2.

Connect the PE cable (green with yellow) to PE busbar plate; fasten input power cable L1 (yellow or brown), L2 (green or black), L3 (red or gray)/Neutral (blue) on input terminal block accordingly. Connect DC+ and DC- power cable of GUN1、GUN2、GUN3 and GUN4 on relative position of busbar. Please fasten each wire with proper bolt and torque -350Kgf•cm/5-15 secs.

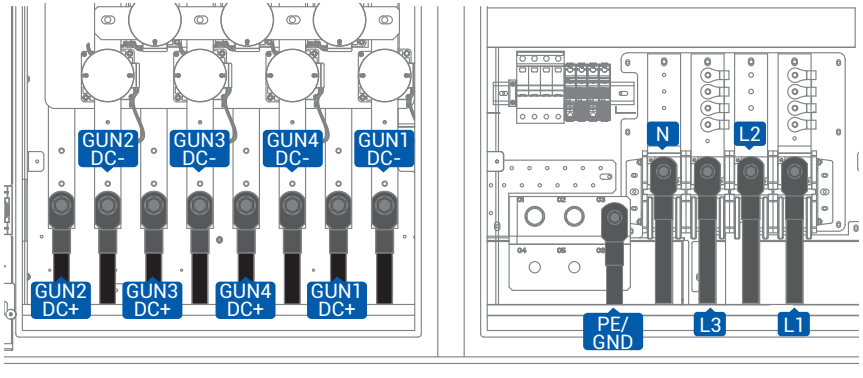

Notes:

1. Precautions for the lock of the lower row of AC terminal blocks: first put the terminal -> copper row -> opening washer -> screw.
2. PE copper busbar: PE/GND is 03. Others are the PE points of the main cabinet and gun cabinet.

STEP 3.

Connect Ethernet cable :
Insert input and output Ethernet cable into paired RJ45 connectors as pictures below .

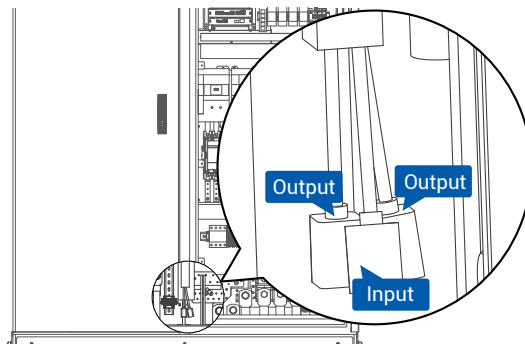

STEP 4.

Connect AC power cables to power distribution box, connect the Protective Earth wire (Green/Yellow) to ground point of power distribution box. Neutral should be shorted with PE to meet TN(-S) grounding system.

STEP 5.

To properly seal the cable entry after cables are installed, please fill and glue the cable entry with the sponge grommets provided in the accessory kit.

STEP 6.

Use adaptive flame retardants and electrical insulated foaming agent and far from conductive live part at least 12mm or other method to seal the cable entry hole to assure the NEMA3R grade of the cabinet, and prevent insects enter the cabinet.



600A NFB B curve, with 30mA RCD type A and power meter are recommended to be used on power distribution box .

Note

Remove the protective antenna EPE.
If remove the eye bolts on the top of the cabinet, must assemble the water-proof plastic bolts (inside the accessory pack).

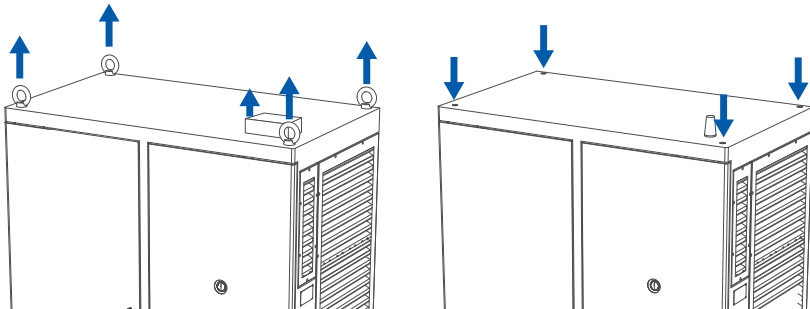

3.6 Installation Inspection & Commissioning

3.6.1 Environmental Check

Item	Status	Remark
Ambient temperature		
Ambient humidity		
Sunshade		Recommended but not required
Rain canopy		Recommended for better charging experience and maintenance on rainy day
Air circulation/Drafty		
Dust level		
Fire control equipment		National regulations
Flood measures		
Car bumper or bollard		
Anti-Vandalism measures		

3.6.2 External Infrastructure Readiness & Check

Item	Status	Remark
Cement (stand) Base		
Input Wirings & Terminals		Type/ Length/cross section
Key & Lock of Cabinet Door		
Fixing Screws		Type /No.
No Fuse Breaker		Current rating of NFB should be over than or equal to 600A (360kW)
Residual Current Device		30mA type A
Input Electricity Capacity		
Input Electricity Connection		Wye
Grounding Resistance		<4Ω
Grounding System		TN/TT
Grid Voltage & Frequency		
Network Connection & Quality		Wi-Fi , 3G/4G > -65dBm

3.6.3 EVSE Check – Static (Non-Powered)

Item	Status	Remark
Outlook		No dent, rust ,scratch
Labeling & Warning Signs		
Package (accessory) List		
Inner Wiring & Connection		See Screw torque table below
Robustness of Input Wirings		
Robustness of output wiring		



WARNING: Improper connection of the EVSE grounding conductor can result in a risk of electric shock. Please ensure the EVSE is properly grounded prior to energize it.

Screw torque requirement table

Screw in Metric						
Screw size	Screw type	Steel Inch-Lbs	Steel kgf-cm	Steel N-m	Aluminum kgf-cm	Aluminum N-m
M2*0.4	Machine	3~4.77	3.5~5.5	0.34~0.54	3~4.5	0.34~0.44
M2.5*0.45	Machine	3~4.77	3.5~5.5	0.34~0.54	3~4.5	0.34~0.44
M3*0.5	Machine	5.5~9	6.5~10.5	0.64~1.04	5.2~8.4	0.51~0.82
M3.5*0.6	Machine	8.5~13	10~15	0.98~1.47	8~12	0.78~1.18
M4*0.7	Machine	13~18	15~21	1.47~2.06	12~17	1.18~1.66
M5*0.8	Machine	25~34	29~39	2.84~3.82	23~32	2.26~3.14
M6*1.0	Machine	45~55	52~63.5	5.1~6.22	42~51	4.11~5
M6*1.0	Hex cap	85~112	98~129	9.6~12.65	78~103	7.65~10.1
M8*1.25	Machine	106~141	122~163	11.96~15.98	98~130	9.61~12.75
M8*1.25	Hex cap	205~274	237~316	23.24~30.98	190~253	18.63~24.8
M10*1.5	Hex cap	212~382	245~440	24.02~43.15	196~351	19.22~34.42
M12*1.75	Hex cap	372~668	430~770	42.17~75.49	343~615	33.63~60.3
Screw in Imperial						
2-56	Machine	1.5~2	1.7~2.3	0.17~0.22	1.4~1.8	0.14~0.18
4-40	Machine	3~4	3.5~4.5	0.34~0.44	2.8~3.6	0.27~0.35
6-32	Machine	6~10	7~11.5	0.68~1.13	5.6~9.2	0.55~0.9
8-32	Machine	10~15	11.5~17	1.13~1.66	9.2~14	0.9~1.37
10-32	Machine	16~24	18.5~28	1.81~2.74	15~22	1.47~2.16
1/4-20	Machine	35~46	40~53	3.92~5.2	32~42	3.14~4.11
1/4-20	Hex cap	57~77	66~89	6.47~8.73	53~71	5.2~6.96
5/16-18	Hex cap	119~158	137~182	13.43~17.85	110~145	10.77~14.21
3/8-16	Hex cap	205~274	237~316	23.24~30.99	190~253	18.63~24.82
7/16-14	Hex cap	338~451	390~521	38.24~51.09	312~416	30.59~40.79
1/2-13	Hex cap	515~686	595~792	58.35~77.66	476~634	46.68~62.17

3.6.4 Power On Check

1. Turn on the external breaker of power distribution box.
2. Open the power cabinet's front door and check light indication status at power dispenser as shown in following.

#	Status Description	RED Light	GREEN Light
1	Start up	Both are blinking	
2	Standby mode	Off	On
3	Warning or Error	On	Off

3. Function check & Connection as list below.

Item	Status	Remark
Network Connection Quality		Wi-Fi , 3G/4G > -65dBm
Cooling Fans Operation & Noise		
EVSE Setting		See chapter 4 or refer to setting manual
Function of Engineer Mode		

3.6.5 EVSE Charging Check

Item	Status	Remark
Full Charge Test		Temperature Reading
Airflow & Noise of Cooling Fan		
Charging Record (log) Upload		

3.6.6 Emergency Stop Test

Item	Status	Remark
Emergency Stop		
Recovery form emergency stop		

4. Charger and Network Setting

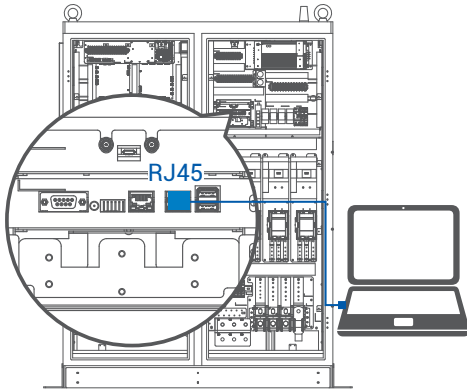

4.1 Wi-Fi Network Setting

- Bring laptop with RJ45 interface.
- Connect RJ45 cable from Laptop to charger's RJ45 port.
- Parameter setup in the Webpage.
- Input RJ45 connector port is for maintenance use for engineer.

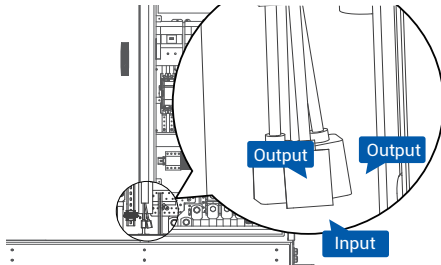

Use the following IP address:

IP address:

Subnet mask:

Default gateway:

Step 1.

Please enter network setting, set your IPV4 static IP to 192.168.1.1 in PC

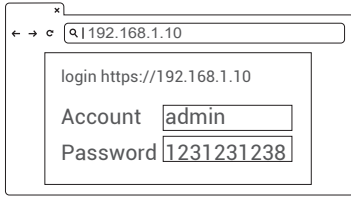

Step 2.

Open web service browser, type the IP address of charger "192.168.1.10" into the URL bar to access the web page of charger.

- Account: admin
- Password: 1231231238

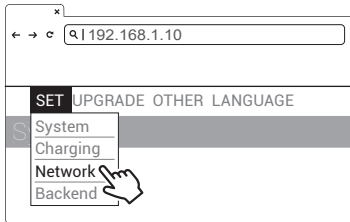

Step 3.

SET -> Network.

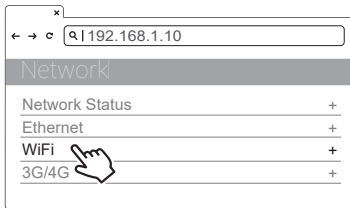

Step 4.

Select Wi-Fi Module

Select Wi-Fi modes and fill in SSID and Password according to your application, if not required, just keep default.

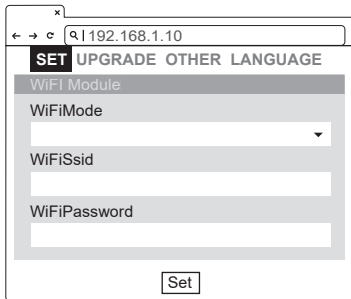

Wi-Fi Setting	Description
WiFi Ssid	Service Set Identifier: SSID
WiFi Password	Password to access to Wi-Fi
WiFi Dhcp Server	DHCP server of Wi-Fi
WiFi Dhcp Client	DHCP client of Wi-Fi
WiFiIpAddress	Wi-Fi IP address
WiFiSubmask Address	Wi-Fi submask address
WiFiGateway Address	Wi-Fi gateway address



WARNING: Due to the different environmental conditions, it is recommended to conduct Wi-Fi and 4G module network signal tests before installation. The RSSI (Received Signal Strength Indication) value suggest to be higher than -65 dBm. If it is lower than this value, it may cause the risk of abnormal Wi-Fi or 4G connection quality or disconnection since the influence of external interference in the environment.

4.2 3G/4G Setting

4.2.1 SIM Card Installation

Step 1.

Open the right door. And you can see the 4G/Wi-Fi module inside the cabinet.

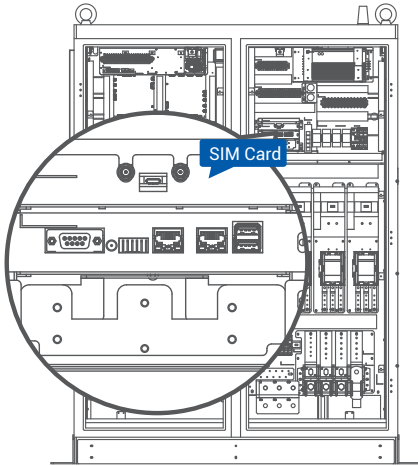

Step 2.

Please disable the PIN on the SIM card before inserting it into the SIM card slot. The chip side should be facing downward and its notch is oriented as shown in the left picture. The slot could be damaged if it is inserted in the wrong direction.

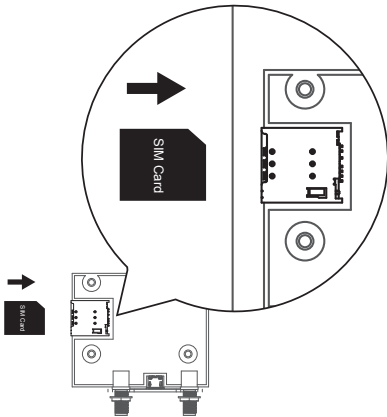

4.2.2 Setting and Enable 3G/4G Module.

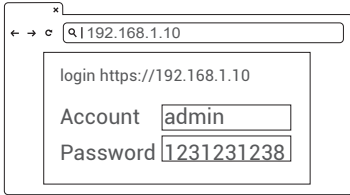

Step 1.

- Please contact your SIM provider to get the APN, PPP ID and password.
- *Note: PPP ID and password maybe options depend on your SIM provider.
- Open the web page of charger and sign-in.

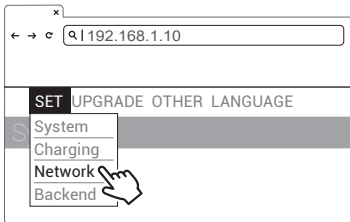

Step 2.

SET -> Network.

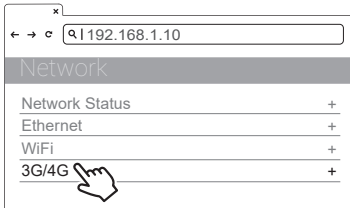

Step 3.

- Network -> 3G/4G Module to fill corresponding information into TelcomApn, TelcomChapPapid and TelcomChapPapPw.
- Please contact your SIM provider to get the APN, PPP ID and password if necessary.
- Click "Set" to finish the setup process. The 3G/4G will be activated in shortly.

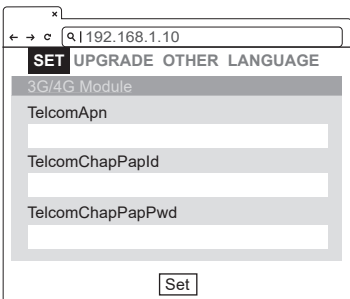

TelcomApn	APN Setting
TelcomChapPapid	Login ID authentication
TelcomChapPapPw	Login password authentication
TelcomIpAddress	IP address

5. Maintenance

5.1 Status Codes

- The detail of status code please refer user manual of dispenser.

5.2 General Maintenance

- Please ensure proper air ventilation surrounding the EVSE units. Do not block the air inlet and outlet grille to allow proper heat dissipation of the EVSE units. Failure to follow the precaution may lead to overheating of the units.



CAUTION : Make sure all maintenance process do follow safety regulation and local electrical code.

- Clean the DC fast Charger at least three times a year, keep the exterior clean at all times.
- Clean the outside of the cabinet with damp cloth or wet cotton towel, only use low-pressure tap water and cleaning agents with PH level between 6 to 8.
- Do not apply high-pressure water jets.
- Do not use cleaning agents with abrasive components and do not use abrasive tools. Improper cleaning agents might spoiled coating, painting, surface, brightness and durability of all exterior parts.
- Please keep the exterior of DC Fast Charger clean at all times and do not spray water directly at the DC Fast Charger.
- If there is water intruding into the DC Fast Charger then please switch off the power source immediately and contact the DC Fast Charger provider for repair.
- Please loop the cable nicely around the bundle and wrap it gently back onto the holder. Please attach the charging connector back to the holster securely.
- If there is damage to the charging connector, charging cable or holder of the charging connector then please contact the DC Fast Charger provider.
- When using the DC Fast Charger please handle properly. Do not strike or scrape the cabinet or screen.
- After open door maintenance, please close and lock the door .
- If the enclosure or screen is broken, cracked, open or shows any other indication of damage then please contact the DC Fast Charger provider.



WARNING: Danger of electrical shock or injury. Turn OFF power before working on the equipment or removing any component. Do not remove circuit protective devices or any other component until the power is turned OFF.

-
- Turn off power distribution cabinet to the Power Cabinet before any maintenance work to ensure it is separated from the supply of AC mains. Failure to do so may cause physical injury or damage to the electrical system and charging unit.
 - During the decommissioning or removal of the EVSE, the grounding conductor should be removed last to prevent an electric shock.

Note:

- Before switching off main breaker to begin any maintenance or service, please record any status code shown in the top section of the display screen of the Power Dispenser for future diagnosis purpose.
- After maintenance door opened and NFB been turned off is still hazardous, only visual inspection can be operated and maintenance of the power cabinet shall be conducted only by a qualified technician.
- Replace the air filter every six to twelve months.

5.3 Replacement Kits and Accessories

The DC EVSE offers the following replacement kits and accessories

Replacement Kit List
Emergency Stop Button
30kW DC PSU U-1K0100
MW Aux. Power HEP-100-12V/24V
Control & Supervisory Unit (CSU3.1)
Surge Protection Device (SPD)
DC Fan
Air Filters
Door Key
User Manual
HV Relay
Fuse
Contactors
WiFi + 3G/4G module
Relay board
Fan board
Hub

6. Limited Product Warranty

1. The product body is made of metal welding and surface painting. When the product placed in a natural environment, different environmental factors will make the surface appear slight rust possibly during warranty period (E.g., acid deposition), it does not affect the charger function.
2. The warranty period of this charger is according to purchasing contract; two years typically. Any spare parts provided by Supplier Technology and used as replacements for repair are covered by a five-year guarantee.
3. Replacement and repair parts manufactured by alternative manufacturers to those on the maintenance parts are only allowed if authorized by Supplier.
4. The housing was made of welding process and surface painting. It is necessary to keep the exterior clean all the time. It's easy to get rusty if not keeping the exterior clean especially in corrosion sensitive environment. Slightly rusty will not affect charger performance, but if charger is serious rusty during or exceed the warranty period, please contact local vendor for instruction.

Warranty Exclusions:

- 1) Damage or rendered non-functional as a result of power surges, lightning, earthquake, fire flood, pest damage, abuse, accident, misuse, negligence or failure to maintain the product or other event beyond Supplier's reasonable control or not arising from normal operating condition.
- 2) Cosmetic or superficial defect, dents, marks or scratches after use.
- 3) Components which are separate from the product, ancillary equipment and consumables, such as door key, RFID card, quick guide, air filter, fuse, cable, wires, coolant in cooling unit and connectors.
- 4) Damage as a result of modifications, alterations or disassembling which were not pre-authorized in writing by Supplier.
- 5) Damage due to the failure to observe the applicable safety regulations governing the proper use of the product.
- 6) Installed or operated not in strict conformance with the documentation, including without limitation, not ensuring sufficient ventilation for the product as described in Supplier installation instruction.
5. If a defect in the product arises and a valid claim is submitted within the warranty period, your sole and exclusive remedy will be for Supplier, at its sole discretion and to extent permitted by law, to
 - 1) Repair the defect in the product at no charge, using new or refurbished parts.

-
- 2) Exchange the product with new or refurbished product that is functionally equivalent to the original product.
 6. Any remedy hardware product will be warranted for the remainder of the original warranty period or 90 days from delivery to the customer, whichever is longer.
 7. In order to receive the remedy set for above, you must contact Supplier during the warranty period and provide the model number, series number, proof of purchase, and date of purchase.
 8. This warranty does not cover the damages result in resulting from adapter accident or damages resulting from unauthorized service.

Appendix 1 - Package list

Item	Description	No.	Remark
1	EVSE-Power Cabinet	1	
2	User manual	1	
3	OQC Report	1	
4	Key of cabinet	1	
5	Waterproof Plastic Bolts	4	
6	SPONGE WIRE LR	2	
7	CAT6A FTP RJ45 Plug	2	
8	M16 X L40 screws assembly	2	

Appendix 2 - Wire and NFB recommendation

(360kW) Pin / 0.94 / 0.99/ Vin(235V) / 3Phase				
UL	Input Current Value(235V) Max.	Max. Input power	Input wire diameter (UL1581)	NFB
180kW	269A	198KVA	100mm ² *2	350A
210kW	320A	231KVA	150mm ² *2	400A
240kW	358A	264KVA	150mm ² *2	400A
270kW	411A	297KVA	200mm ² *2	500A
300kW	448A	330KVA	250mm ² *2	500A
330kW	502A	363KVA	250mm ² *2	600A
360kW	573A	396KVA	250mm ² *2	700A



Manufacturer Contact Info Sticker

